

RAIN SENSOR

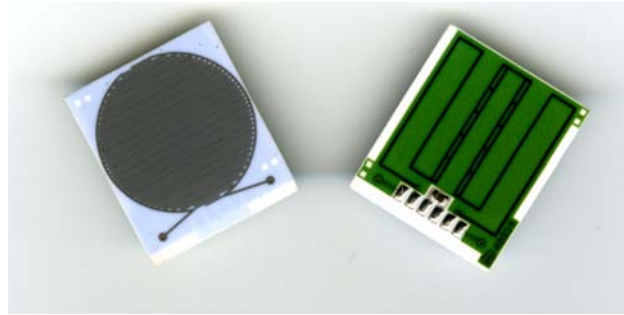

Telecontrolli, leader in thick film technology, has recently realized a component to be able to employ in devices that notice the presence of rain to the ground.

These devices, commonly suitable as "rain sensor", always find greater employment in sectors in which they were already known (meteorology, agriculture), but even more they are spreading in applications of automation, both domestic (curtains, windows, skylights, etc.) how industrial component.

Rain sensor, is realized on ceramic substrate (Alumina), material endowed with great reliability both from the mechanical point of view that thermal-electrical.

It is based on the capacitive principle, so the rain drops that accumulate on the surface of reading change the electric capacity of the sensor, noticing so the presence of rain.

Heating circuit mounted on back's device, guarantees the exact survey of the phenomenon "rain" avoiding wrong signalings due to accumulations of nighttime damp or morning frosts.

The employed technology (glassy coverage of substrate) guarantees high reliability due to the great stability of the support and the inalterability of the surface "sensitive", also after cleaning with solvents and/or heavy external conditions of employment.

Principle of Operation:

Capacitive

Technology:

Thick Film on Allumina (Al_2O_3) substrate.

Typical Applications:

Meteorological Stations

Control Systems in Home & Building Automation, Industrial Automation,

Agriculture Automation & Monitoring

Mechanical Dimensions mm [Inch] *

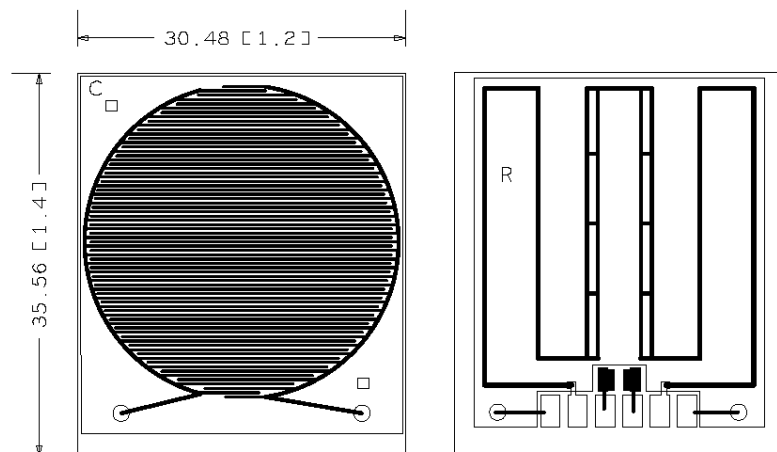

Electrical Parameters

Capacity (nom.):	100 pF 10%
R (heater):	42 ohm 10% ($P_R = 3,5$ Watt with $V_{Supply} = 12V$, $I = 292mA$, $T_f = 106^\circ C$)
NTC:	1Kohm to 10 Kohm / $25^\circ C$

Provided with Heater and NTC for Temperature Regulation

*Mechanical dimensions can be customized according to project requirements, in line with the design constraints.